

RESISTIVE ATTENUATORS

- **T-Attenuator** - Consists of two series arm resistors (R1 and R2) and one parallel resistor (R3). As with the PI-Attenuator, this type of attenuator is considered unbalanced. If this attenuator is designed with Z1 and Z2 equal, R1 and R2 will also be equal, and the configuration will be symmetrical. Being symmetrical makes the T-Attenuator ideal for insertion between two equal impedances ($Z1 = Z2$), to reduce signal levels.
- **H-Attenuator** - Consists of two series arm resistors (R1 and R2, R4 and R5) and one parallel resistor (R3). This type of attenuator is considered Balanced and is commonly designed with Z1 and Z2 equal.
- **PI-Attenuator** - Consists of two series arm resistors (R1 and R2) and one parallel resistor (R3). This type of attenuator is considered unbalanced and is commonly designed with Z1 and Z2 equal. This configuration is then symmetrical as R1 and R2 are equal values.

The attenuator resistor values in the table are given for a 50-ohm system as this is the most likely impedance system required. However, it is recognized that other impedance systems may also be used.

To convert the values in the table to another value of impedance, they should be multiplied by the factor $Z / 50$, where Z is the characteristic impedance of the required system.

NOTE: Attenuation levels above 20 dB per section are not advised as leakage and other issues mean that the performance is unlikely to be as good. If higher values of attenuation are required, then it is suggested that several sections of 20 dB or less are used - typically the level of attenuation is averaged over each section.

T-Attenuator:

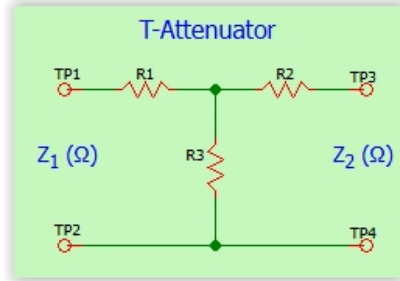

Equations

For: $K = 10^{\text{db}/20} = 10.0000$

$$R_3 = 2 \times \sqrt{Z_1 \times Z_2} \times \frac{K}{K^2 + 1}$$

$$R_1 = Z_1 \times \frac{K^2 + 1}{K^2 - 1} - R_3$$

$$R_2 = Z_2 \times \frac{K^2 + 1}{K^2 - 1} - R_3$$

50 ohm Resistive Attenuator Chart (1% resistors)							
Atten.	R1	R2	R3	Atten.	R1	R2	R3
1 dB	2.9 Ω	2.9 Ω	442 Ω	16 dB	37 Ω	37 Ω	17 Ω
2 dB	5.8 Ω	5.8 Ω	221 Ω	18 dB	39 Ω	39 Ω	13 Ω
3 dB	8.7 Ω	8.7 Ω	143 Ω	20 dB	41 Ω	41 Ω	10 Ω
4 dB	12 Ω	12 Ω	105 Ω	22 dB	43 Ω	43 Ω	8.1 Ω
5 dB	14 Ω	14 Ω	83 Ω	24 dB	44 Ω	44 Ω	6.3 Ω
6 dB	17 Ω	17 Ω	68 Ω	26 dB	45 Ω	45 Ω	5.1 Ω
7 dB	20 Ω	20 Ω	56 Ω	28 dB	46 Ω	46 Ω	4.0 Ω
8 dB	22 Ω	22 Ω	48 Ω	30 dB	48 Ω	48 Ω	3.2 Ω
9 dB	24 Ω	24 Ω	41 Ω	32 dB	49 Ω	49 Ω	2.6 Ω
10 dB	26 Ω	26 Ω	36 Ω	34 dB	49 Ω	49 Ω	2.0 Ω
11 dB	29 Ω	29 Ω	31 Ω	36 dB	49 Ω	49 Ω	1.6 Ω
12 dB	30 Ω	30 Ω	27 Ω	38 dB	49 Ω	49 Ω	1.3 Ω
14 dB	34 Ω	34 Ω	21 Ω	40 dB	49 Ω	49 Ω	1.0 Ω

50 ohm Resistive Attenuator Chart (5% resistors)							
Atten.	R1	R2	R3	Atten.	R1	R2	R3
1 dB	3.0 Ω	3.0 Ω	470 Ω	16 dB	39 Ω	39 Ω	18 Ω
2 dB	6.2 Ω	6.2 Ω	220 Ω	18 dB	39 Ω	39 Ω	13 Ω
3 dB	9.1 Ω	9.1 Ω	150 Ω	20 dB	43 Ω	43 Ω	11 Ω
4 dB	12 Ω	12 Ω	110 Ω	22 dB	43 Ω	43 Ω	8.2 Ω
5 dB	15 Ω	15 Ω	91 Ω	24 dB	47 Ω	47 Ω	6.8 Ω
6 dB	18 Ω	18 Ω	68 Ω	26 dB	47 Ω	47 Ω	5.1 Ω
7 dB	20 Ω	20 Ω	56 Ω	28 dB	47 Ω	47 Ω	4.3 Ω
8 dB	22 Ω	22 Ω	51 Ω	30 dB	47 Ω	47 Ω	3.3 Ω
9 dB	24 Ω	24 Ω	43 Ω	32 dB	51 Ω	51 Ω	2.7 Ω
10 dB	27 Ω	27 Ω	36 Ω	34 dB	51 Ω	51 Ω	2.0 Ω
11 dB	30 Ω	30 Ω	33 Ω	36 dB	51 Ω	51 Ω	1.6 Ω
12 dB	30 Ω	30 Ω	27 Ω	38 dB	51 Ω	51 Ω	1.3 Ω
14 dB	36 Ω	36 Ω	22 Ω	40 dB	51 Ω	51 Ω	1.0 Ω

H-Attenuator (Ballanced):

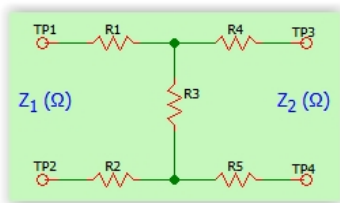

The same values as T-Attenuator above, but R1 and R2 are split into 2 equal resistors forming an H.

Pi-Attenuator:

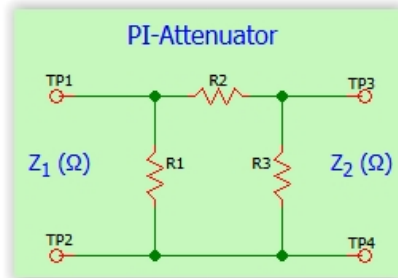

Equations

For: $K = 10^{\text{db}/20} = 10.0000$

$$Z = Z_1 = Z_2$$

$$R_2 = Z \times \frac{K^2 - 1}{2 \times K}$$

$$R_1 = R_3 = Z \times \frac{K + 1}{K - 1}$$

50 ohm Resistive Attenuator Chart (1% resistors)							
Atten.	R1	R2	R3	Atten.	R1	R2	R3
1 dB	887 Ω	5.9 Ω	887 Ω	16 dB	70 Ω	154 Ω	70 Ω
2 dB	442 Ω	12 Ω	442 Ω	18 dB	65 Ω	196 Ω	65 Ω
3 dB	294 Ω	18 Ω	294 Ω	20 dB	62 Ω	249 Ω	62 Ω
4 dB	221 Ω	24 Ω	221 Ω	22 dB	59 Ω	316 Ω	59 Ω
5 dB	182 Ω	31 Ω	182 Ω	24 dB	58 Ω	402 Ω	58 Ω
6 dB	154 Ω	37 Ω	154 Ω	26 dB	56 Ω	511 Ω	56 Ω
7 dB	133 Ω	45 Ω	133 Ω	28 dB	55 Ω	634 Ω	55 Ω
8 dB	118 Ω	54 Ω	118 Ω	30 dB	54 Ω	806 Ω	54 Ω
9 dB	105 Ω	62 Ω	105 Ω	32 dB	54 Ω	1000 Ω	54 Ω
10 dB	98 Ω	72 Ω	98 Ω	34 dB	52 Ω	1270 Ω	52 Ω
11 dB	91 Ω	83 Ω	91 Ω	36 dB	52 Ω	1580 Ω	52 Ω
12 dB	85 Ω	96 Ω	85 Ω	38 dB	52 Ω	2000 Ω	52 Ω
14 dB	75 Ω	121 Ω	75 Ω	40 dB	51 Ω	2550 Ω	51 Ω

50 ohm Resistive Attenuator Chart (5% resistors)							
Atten.	R1	R2	R3	Atten.	R1	R2	R3
1 dB	910 Ω	6.2 Ω	910 Ω	16 dB	75 Ω	160 Ω	75 Ω
2 dB	470 Ω	12 Ω	470 Ω	18 dB	68 Ω	200 Ω	68 Ω
3 dB	300 Ω	18 Ω	300 Ω	20 dB	62 Ω	270 Ω	62 Ω
4 dB	240 Ω	24 Ω	240 Ω	22 dB	62 Ω	330 Ω	62 Ω
5 dB	180 Ω	33 Ω	180 Ω	24 dB	62 Ω	430 Ω	62 Ω
6 dB	160 Ω	39 Ω	160 Ω	26 dB	56 Ω	510 Ω	56 Ω
7 dB	150 Ω	47 Ω	150 Ω	28 dB	56 Ω	680 Ω	56 Ω
8 dB	120 Ω	56 Ω	120 Ω	30 dB	56 Ω	820 Ω	56 Ω
9 dB	110 Ω	62 Ω	110 Ω	32 dB	56 Ω	1000 Ω	56 Ω
10 dB	100 Ω	75 Ω	100 Ω	34 dB	56 Ω	1300 Ω	56 Ω
11 dB	91 Ω	82 Ω	91 Ω	36 dB	56 Ω	1600 Ω	56 Ω
12 dB	91 Ω	100 Ω	91 Ω	38 dB	56 Ω	2000 Ω	56 Ω
14 dB	75 Ω	130 Ω	75 Ω	40 dB	56 Ω	2700 Ω	56 Ω

Bridged T-Attenuator:

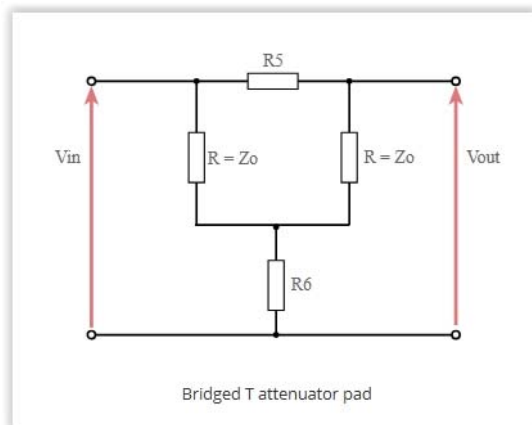

**RF ATTENUATOR PAD RESISTOR VALUES TABLE
FOR 50Ω CHARACTERISTIC IMPEDANCE**

LOSS IN DB	R5	R6
1	6.1	410
2	12.9	193
3	20.6	121
4	29.3	85.4
5	38.9	64.3
6	48.9	50.3
7	61.9	40.4
8	75.6	33.0
9	90.9	27.5
10	108	23.2
11	128	19.6
12	149	16.8
13	173	14.4
14	201	12.4
15	231	10.8
16	265	9.4
17	304	8.2
18	347	7.2
19	396	6.3
20	450	5.6

MERGED ATTENUATOR TABLES (For Comparison)

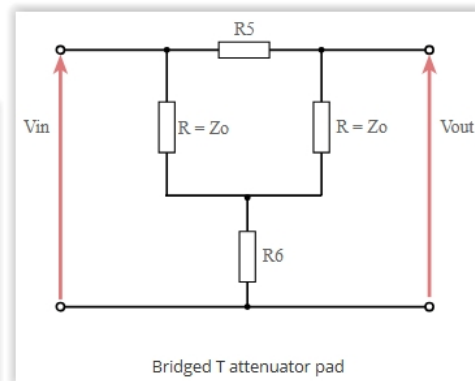
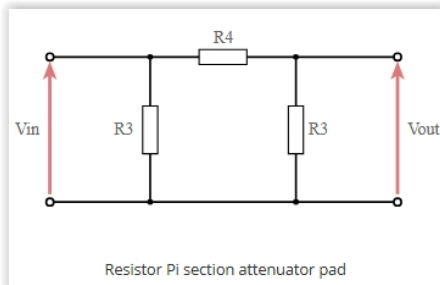
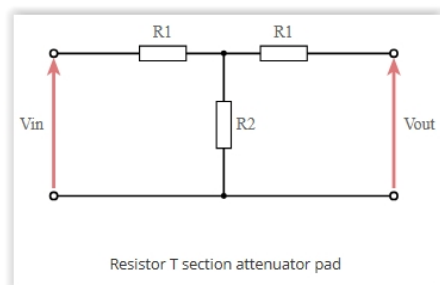

**RF ATTENUATOR PAD RESISTOR VALUES TABLE
FOR 50Ω CHARACTERISTIC IMPEDANCE**

LOSS IN DB	R1	R2	R3	R4	R5	R6
1	2.9	433	870	5.8	6.1	410
2	5.7	215	436	11.6	12.9	193
3	8.5	142	292	17.6	20.6	121
4	11.3	105	221	23.8	29.3	85.4
5	14.0	82.2	179	30.4	38.9	64.3
6	16.6	66.9	151	37.3	48.9	50.3
7	19.1	55.8	131	44.8	61.9	40.4
8	21.5	47.3	116	52.8	75.6	33.0
9	23.8	40.6	105	61.6	90.9	27.5
10	26.0	35.1	96.2	71.2	108	23.2
11	28.0	30.6	89.2	81.7	128	19.6
12	29.9	26.8	83.5	93.2	149	16.8
13	31.7	23.6	78.8	106	173	14.4
14	33.4	20.8	74.9	120	201	12.4
15	34.9	18.4	71.6	136	231	10.8
16	36.3	16.3	68.8	154	265	9.4
17	37.6	14.4	66.5	173	304	8.2
18	38.8	12.8	64.4	195	347	7.2
19	39.9	11.4	62.6	220	396	6.3
20	40.9	10.1	61.1	248	450	5.6

The values given in the table above for the resistive attenuator resistor values provides an easy look-up table. It provides an 'at a glance' view of the resistor values needed for Pi, T and Bridged T resistive attenuator pads, enabling an easy selection of the values as well as the most appropriate type of pad according the resistor values that may be available.

To convert the values in the table to another value of impedance, they should be multiplied by the factor $Z / 50$, where Z is the characteristic impedance of the required system.